



2/3/2025

PBI PICKLEBALL POSTS

Installation, Operation &
Maintenance Manual

PLAY HARD SPORTS EQUIPMENT

13 Alex Fisher Drive
Burleigh Heads, QLD 4220

Contents

Introduction	2
Product Details:	2
Safety Information for the Installer:	3
Important Safety Information	3
Assembly Precautions.....	3
Site Specific Precautions:.....	3
Component List.....	4
Installation Instructions:	5
Unit Assembly Details	9
1. PBI Footing and Assembly Details	9
2. PBI-BP Footing and Assembly Details.....	10
3. PBI-F Assembly Details	10
Maintenance:.....	11
Safety Guidelines (Usage)	11
Certificate of Compliance:	12
Warranty Certificate:	13

Introduction

Thank you for choosing the Pickleball Internal Winder Posts from Play Hard Sports Equipment Australia. Our Pickleball Internal Winder Posts are designed for durability and performance. This manual provides detailed information on the installation, maintenance, usage, and warranty details of the Pickleball Internal Winder Posts supplied by Play Hard Sports Equipment Australia.

Product Details:

Pickleball Internal Winder Posts, designed and manufactured by Play Hard Sports Equipment in Australia using Structural Grade Galvanised Steel, are premium-quality net posts intended for performance, and ease of use in various environments, including corrosive coastal areas. It features an internal winder mechanism with a removal winder handle. The handle sits flat on the face of the post as a result, it increases the safety of the product. If necessary, the winder handle can always be removed and stored in a safe place.

Product Specifications:

- **Models:**
 - PBI
 - PBI-BP
 - PBI-F (Free Standing Pickleball)
- **Footing Option:**

Depending on the model, the posts can be installed into a ground sleeve, base-plated with chemset anchor studs, and free-standing.
- **Footing Size:** 450 Diameter 600mm Deep Bored Pier with N20 Concrete.
- **Ground Sleeve:**
 - EP75 PVC Ground Sleeve & EL75 Drop-in Cap.
 - EHC75p PVC Ground Sleeve with Hinged Lid
 - EHC75s Steel Ground Sleeve with Hinged Lid
- **Material:** 8000 ULTRAGAL C350 steel.
- **Net:**

PB Net – 6650 mm wide with a 700mm drop.
- **Color Options:** Standard Hi-Gloss Black Paint. Various paint colours are available on request.
- **Padding Options:** TP75SQ
 - Padding is available on request.
 - Multiple colours are available, and your logo can be added too.

Apart from our standard product range, we offer custom Tennis Posts based on site-specific requirements. Please get in touch with our team for further details.

All our product footings have been engineered to be suitable for site soil classification as Class 'A', 'S' & 'M' per AS2870. Site-specific footing and slab engineering must be done for other Soil Classes. We also offer site-specific engineering drawings if required for an additional charge.

Safety Information for the Installer:

Important Safety Information

- **Read the Manual:** Ensure you read this manual in full before beginning assembly or installation.
- **Supervision:** Children should be supervised around the tower location during and after installation.
- **Wear Safety Gear:** Always wear appropriate safety gear during assembly and installation.
- **Avoid Electrical Hazards:** Keep electrical tools away from the goalposts and ensure the work area is dry.

Assembly Precautions

- **Check Parts:** Verify all parts are present and undamaged before starting assembly. Some parts are preassembled, and the handle is packed inside the post.
- **Level Ground:** Assemble on a flat surface to avoid instability.

Site Specific Precautions:

- Before commencing any groundwork, please survey the ground/field for underground electrical, water, or sewage lines.
- It is advised that the soil is tested to know its strength. All our towers have been structurally designed to suit 'A', 'S' & 'M' Soils per AS2870. The contractors/installers must notify Play Hard Sports Equipment of any changes to the site specification. All other soil sites would require site-specific footing and slab engineering design.
- The concrete must be of a minimum 20 MPA, with a slump of 80 – 100 mm, and a maximum aggregate of size 20mm.
- Let the concrete set for at least 4 days before commencing further work.

Component List

Components	QTY		
	PBI	PBI-BP	PBI-F
Non-Winder Post	1	1	1
Winder Post	1	1	1
Internal Mechanism	1	1	1
Post Caps	2	2	2
Tennis Post Collar	2	-	-
Ground Sleeve	2	-	-
Sleeve Cap	2	-	-
Support Bar	-	-	1
75 mm dia. Castor with Brake	-	-	1
75 mm dia. Castor without Brake	-	-	1
M10 x 100 mm S/S Hex Bolt, Double Flat Washer, S/Washer & Nut	-	-	8
M12 x 110 mm Gal Hex Bolt, Double Flat Washer & Nyloc Nut	-	-	4

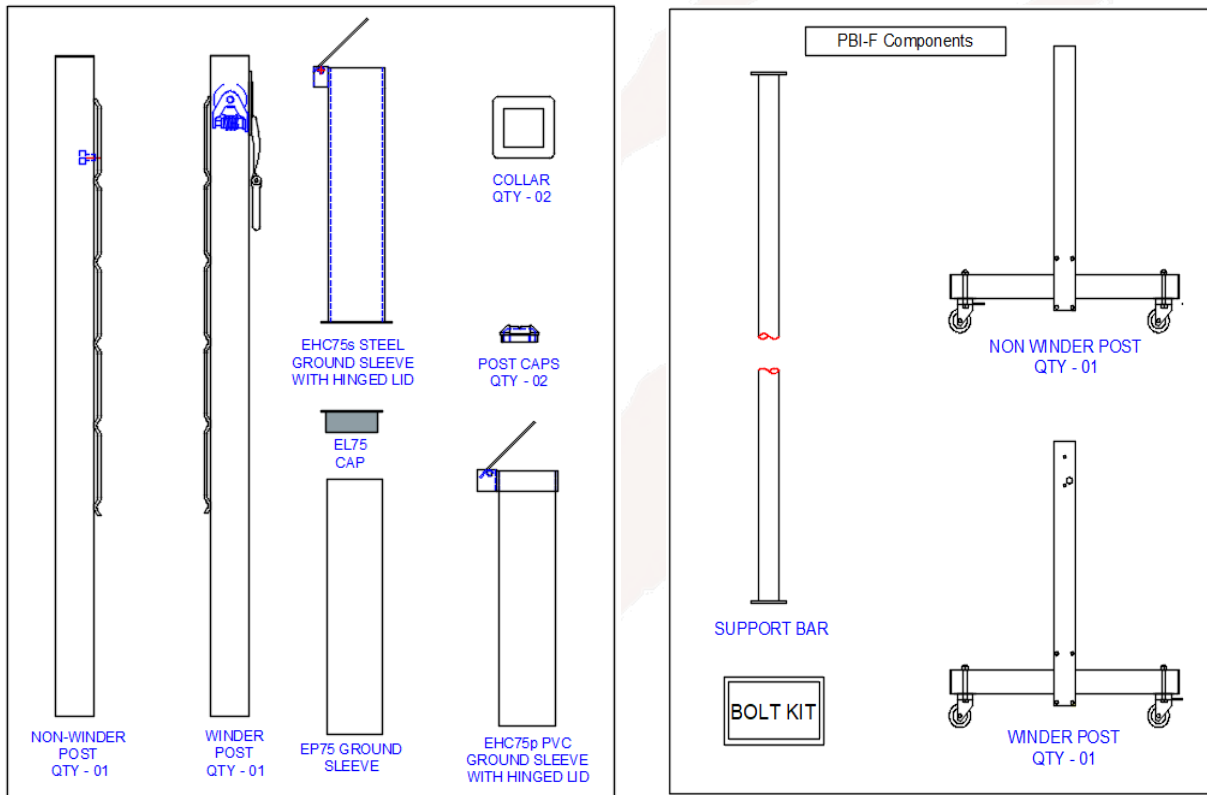

Figure 1: Typical Pickleball Packing List

Note: *The Internal Winder Mechanism comes pre-installed inside the Active Post. The Winder Handle is stored inside the post. Please look inside the post for the handle.*

Installation Instructions:

1A. Site Preparation:

- Before commencing any groundwork, please survey the ground/field for any underground electrical line, water line and sewage line.
- It is advised that the soil is tested to know its strength. All our towers have been structurally designed to suit 'A', 'S' & 'M' Soils per AS2870. The contractors/installers must notify Play Hard Sports Equipment of any changes to the site specification. All other soil sites would require site-specific footing and slab engineering design.

1B. Post Installation:

A. EP75 Sleeve & EL75 Cap:

- Bore Drill 2 x 450 mm Diameter and 600 mm Deep Holes.
- Install the ground sleeves into the hole and keep them levelled and centred to the hole.
- *Please refer to Figures 2,3 & 4 for further details. The ground sleeves must be installed in a specific orientation as shown in Figure 5 and it is the Installer/Contractor's responsibility to ensure that.*
- Pour the concrete into the hole. (*Prevent any concrete from getting inside the ground sleeve*).
- Ensure the sleeve is fixed while pouring the concrete into the hole.
- The concrete must be of a minimum 20 MPA, with a slump of 80 – 100 mm, and a maximum aggregate of size 20mm.
- While the concrete mix is still fresh, use spirit level to check that the ground sleeve is level in all axes.
- Let the concrete set for at least 4 days before commencing further work.

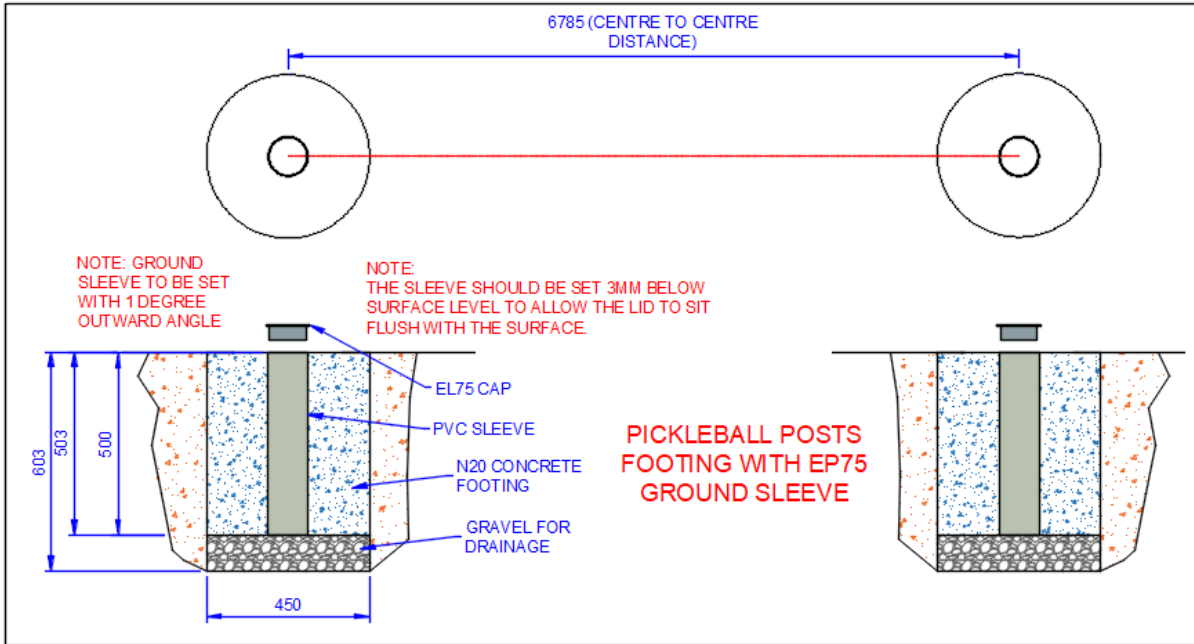

Figure 2: EL75 Cap Footing Details

B. EHC75p and EHC75s:

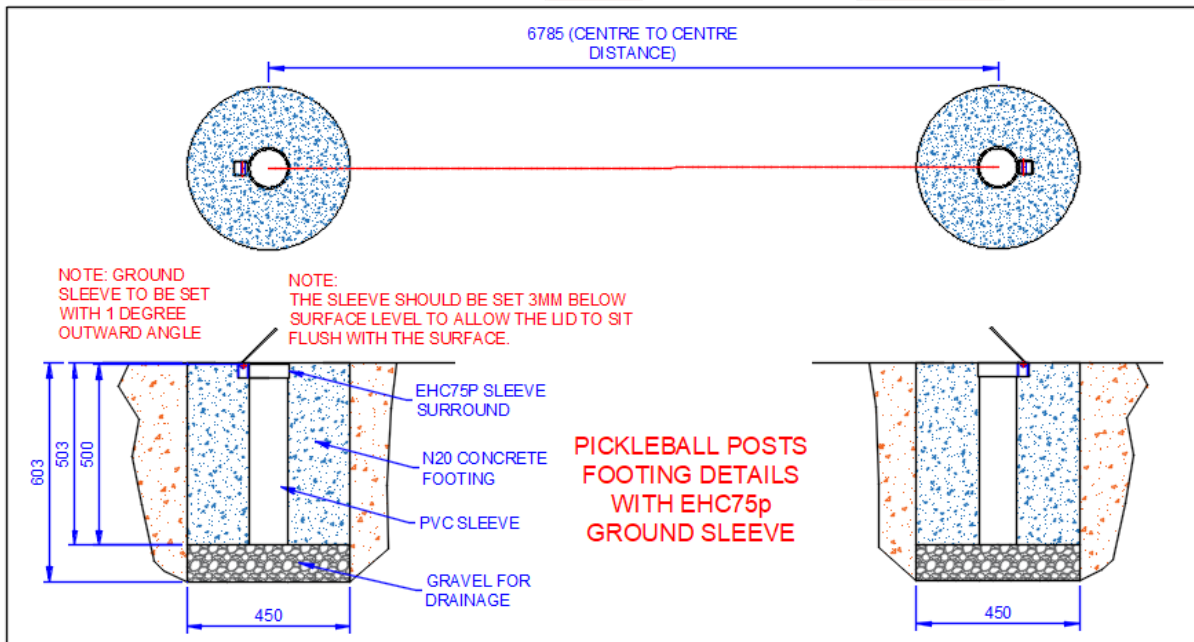

Figure 3: EHC75p Footing Details

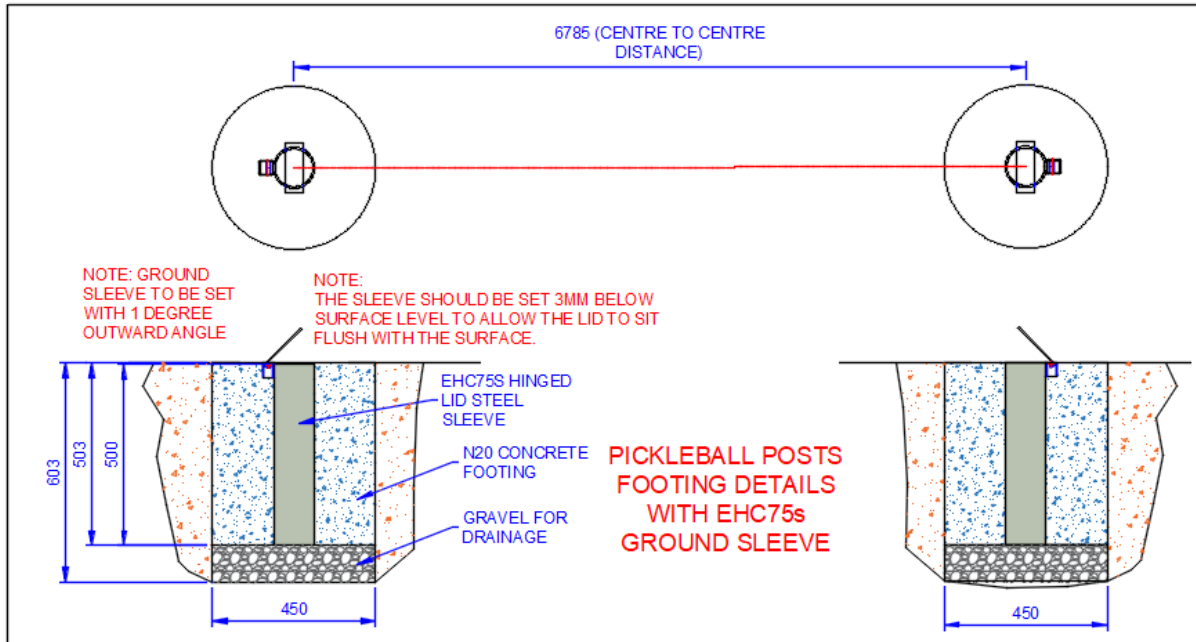

Figure 4: EHC75s Footing Details

C. Free Standing Post Installation:

- The castor wheels are already fitted to the end posts.
- Use the supplied bolts to connect the winder and non-winder posts to the support bar.

2. Net Installation:

1. Once the concrete is set and the court surface has been layered, install the post into the ground sleeves with the wave rails in the posts facing each other.
2. The non-winder post has an internal hook whereas the winder post has an internal mechanism with a nameplate
3. Lay the net across the centre of the courts. The swaged end of the net cable should be on the non-winder side whereas the non-swaged end of the net cable should be on the winder side.
4. Feed the swaged end of the cable through the non-winder post and onto the internal post hook.
5. Feed the non-swaged end of the cable through the post cap and into the drum gear (no need to cut the excess cable off).
6. Tension the cable by hand pulling so there is minimum cable to wind around the drum.
7. Then insert the handle into the slot in the nameplate and turn it to take up the cable tension. The drum will only need a few revolutions to tension the cable.

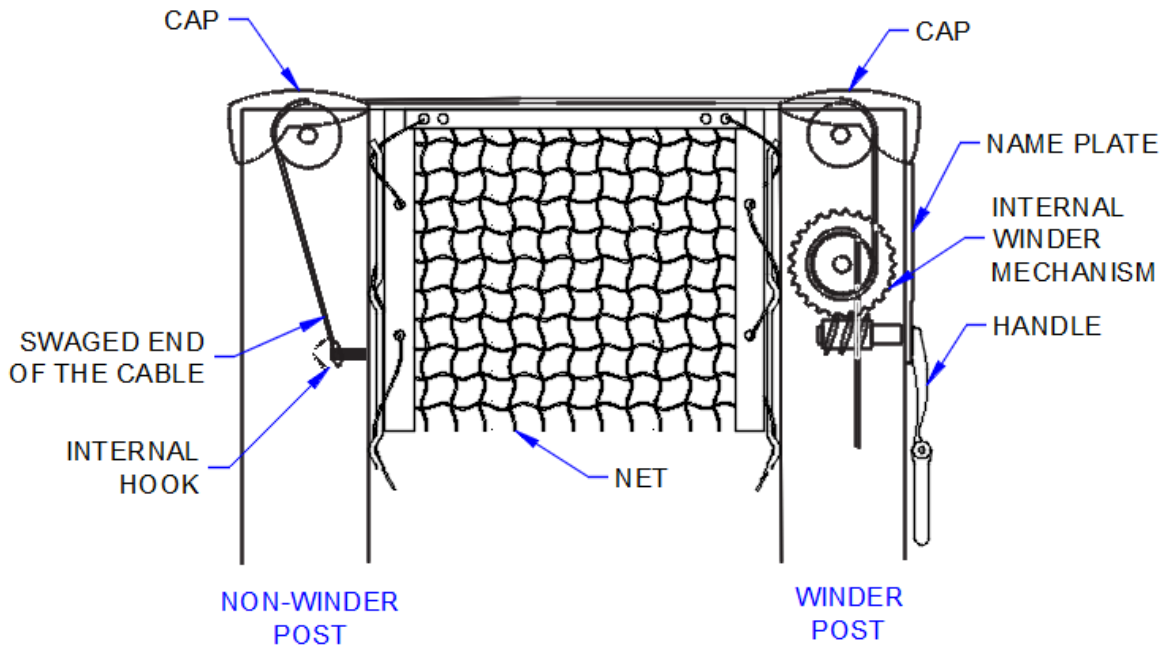

Figure 5: Net Installation Details

Unit Assembly Details

1. PBI Footing and Assembly Details

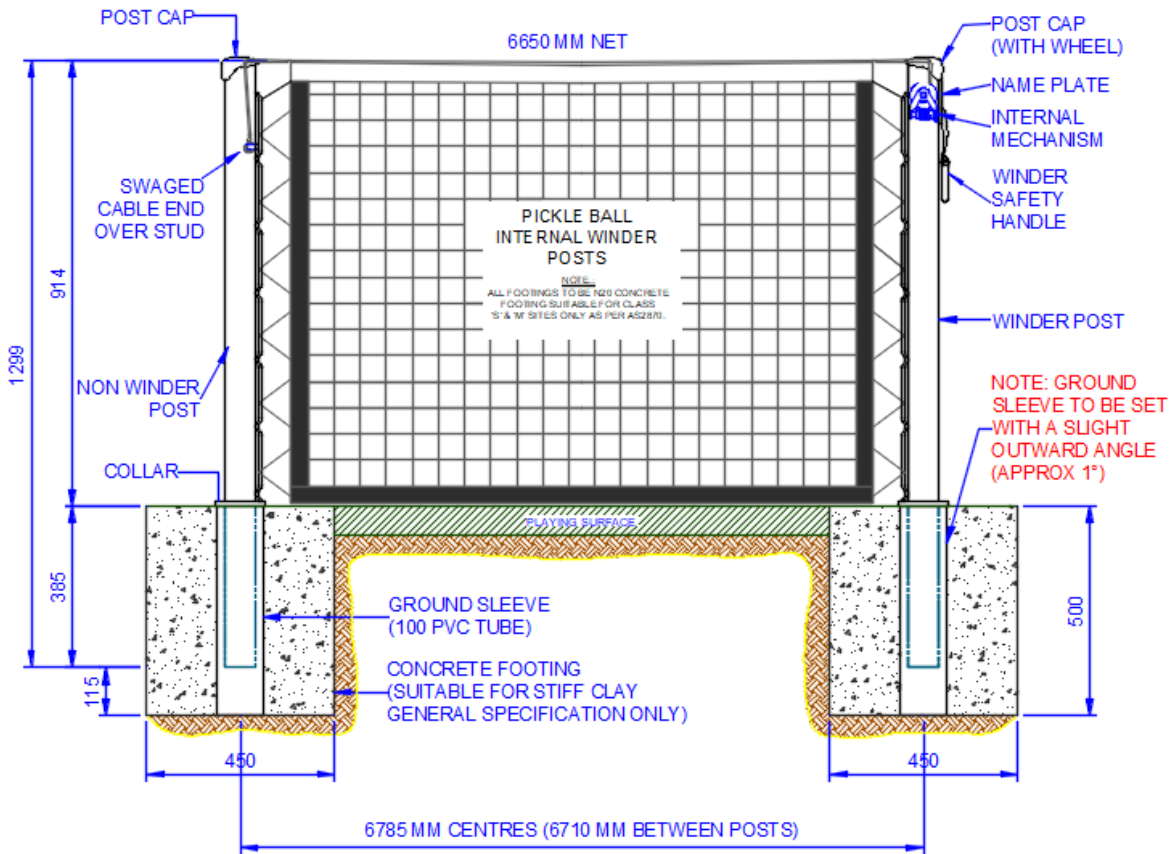

Figure 6: PBI Footing & Assembly Details

2. PBI-BP Footing and Assembly Details

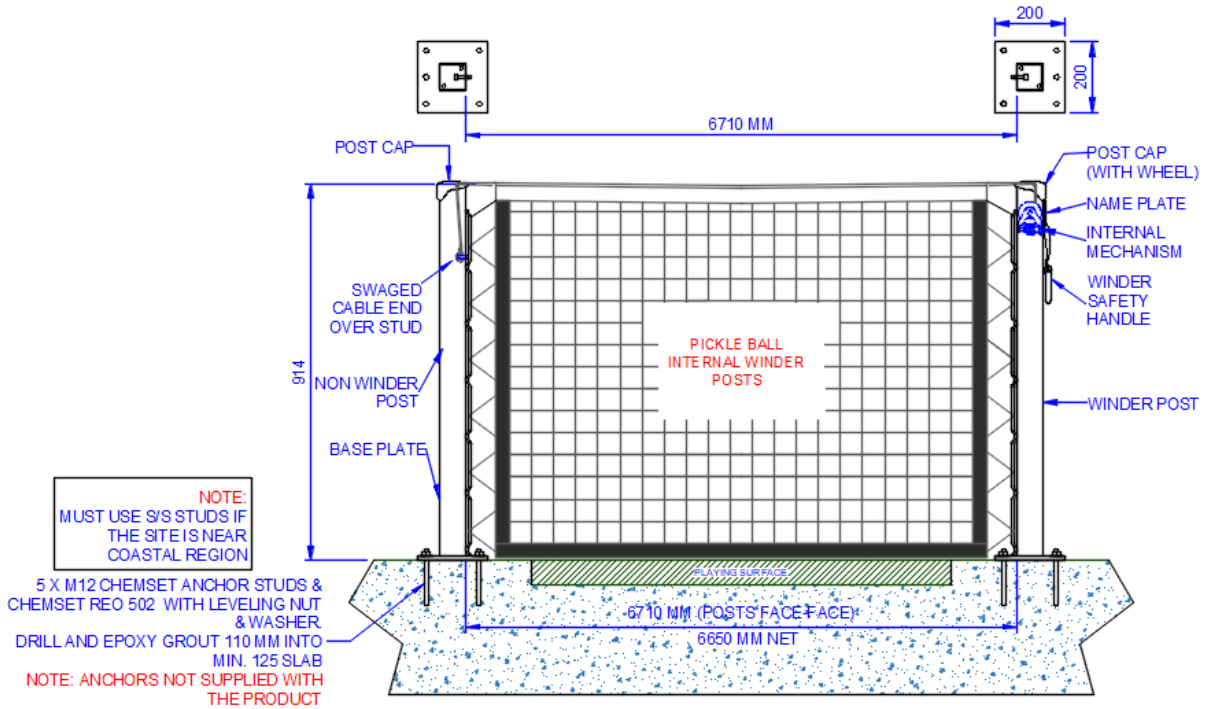

Figure 7: PBI-BP Footing and Assembly Details

3. PBI-F Assembly Details

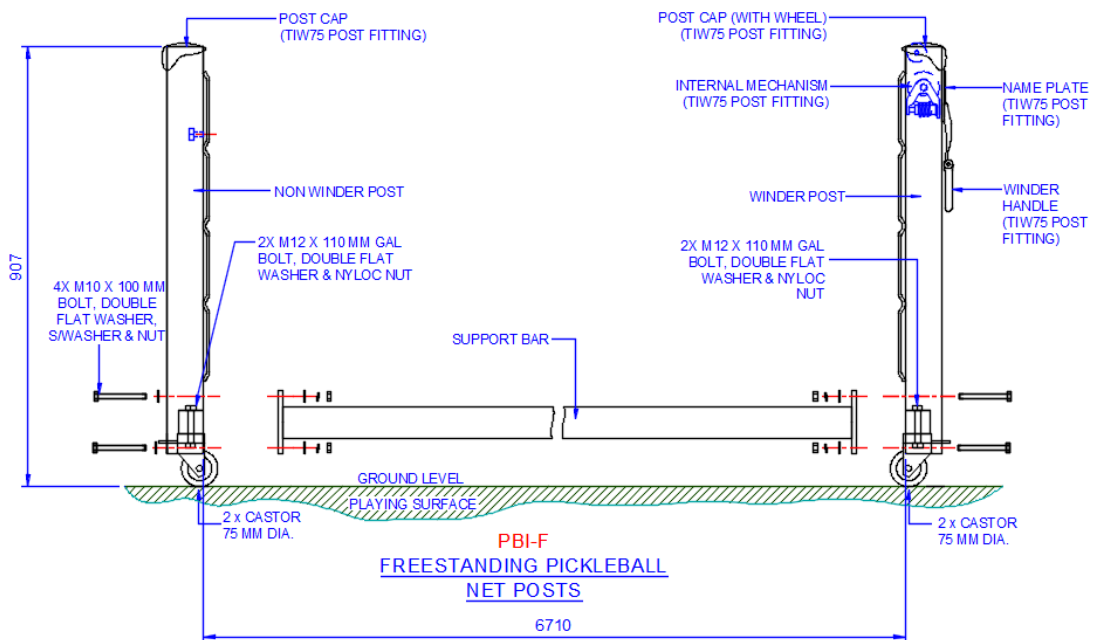

Figure 8: PBI-F Assembly Details

13 Alex Fisher Drive, Burleigh Heads, QLD 4220 (Australia)

Ph: 1300 851 518 | +61 7 5593 4494

Email: email@playhardsports.com.au | W: www.playhardsports.com.au

Maintenance:

All our towers are designed to require a minimal level of maintenance. However, it is advisable to do:

- **Regular Inspections:** Check for any signs of wear or damage. Tighten bolts on the winder mechanism and replace nets or padding as needed.
- Apply a small amount of grease to the internal winder mechanism yearly or when required.
- **Cleaning:** Clean the posts with a damp cloth to remove dirt. Avoid harsh chemicals that could damage the paint. If the poles have been scratched over the intended period of use, lightly scuff the area and apply 2 coats of black gloss paint (spray painted) or your choice of color.
- **Weather Protection:** Consider using protective covers during extreme weather to extend the lifespan of the equipment.

Safety Guidelines (Usage)

The owner of this equipment is responsible for ensuring all players are aware of these conditions for the safe use and operation of the equipment.

1. **Padding (If in Use):**
 - Ensure padding is securely attached to reduce injury risk.
2. **Supervision:**
 - Supervise play, especially with younger players, to ensure safety.
 - Prevent players from hanging from the ring or climbing up the posts to prevent serious injury.
3. During visual inspection, if the bolts are loosened or the post or footing is damaged, the pickleball system should not be used until they have been repaired.
4. Securely store the winder handle when not in use.

Certificate of Compliance:

All our products have been structurally designed and are made using structural-grade steel. All the workmanship is completed following the relevant Australian Standards. Our Products comply with the following Australian Standards.

1. AS/NZS 4100:1998 Steel Structures
2. AS/NZS 1554.1:2014 Welding of steel structures
3. AS/NZS 2312.1:2017 Guide to the protection of structural steel against atmospheric corrosion by the use of protective coatings
4. AS/NZS 2311:2017 Guide to the paintings of buildings

All our products are designed and manufactured here in Australia.



Warranty Certificate:



When you purchase a Play Hard Sports Equipment product you have the peace of mind in knowing that your product is covered by Play Hard Sports Equipment's manufacturer's warranty against faulty workmanship and materials.

The Tennis Posts has 10 years of warranty. The nets are covered by 2 years of manufacturer's warranty.

The warranty covers damage or failure of the product during normal intended use. The warranty does not include damage to the product resulting from accident, misuse, improper installation, operation, or unauthorised repair or alteration. Products manufactured for home use are not guaranteed for use in commercial applications.

If the product should become defective within the warranty period, please get in touch with Play Hard Sports Equipment customer service:

24 Ern Harley Drive

Burleigh Heads QLD 4220

Ph: (07) 55934494

Fax: (07) 55934338

Email: email@playhardsports.com.au