

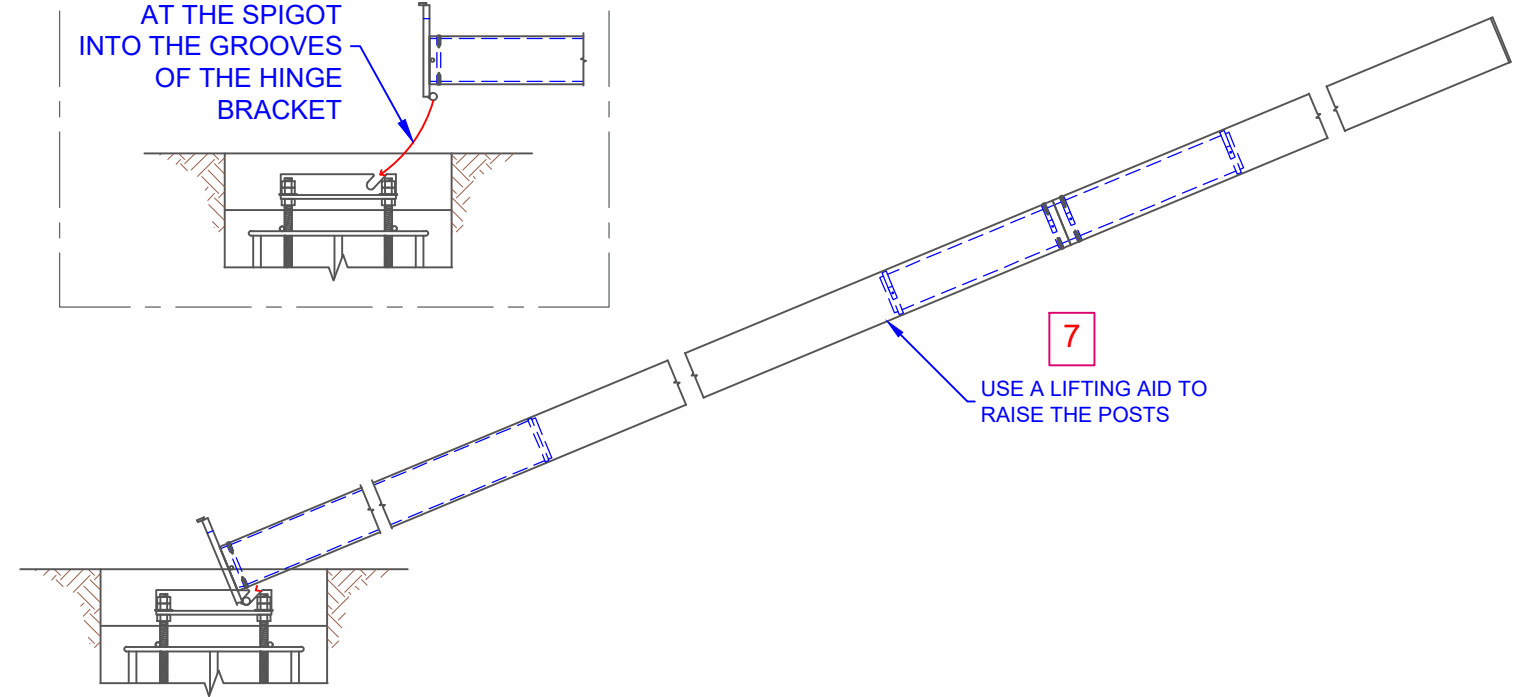

ASSEMBLY INSTRUCTIONS : POST INSTALLATION

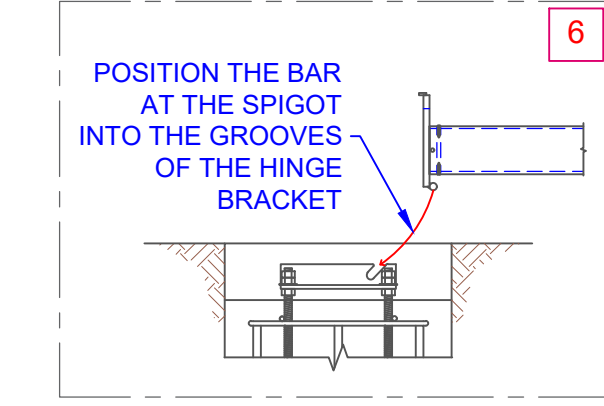
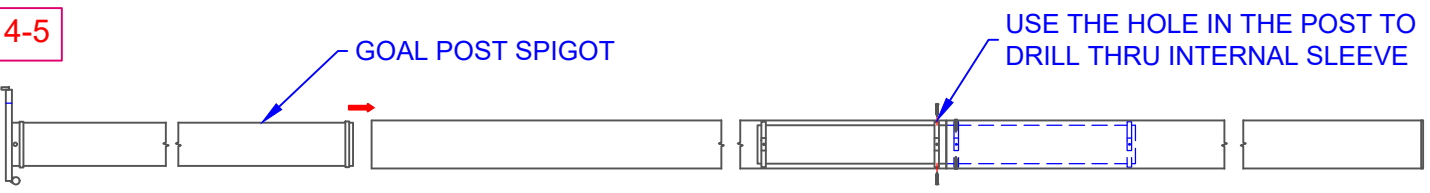
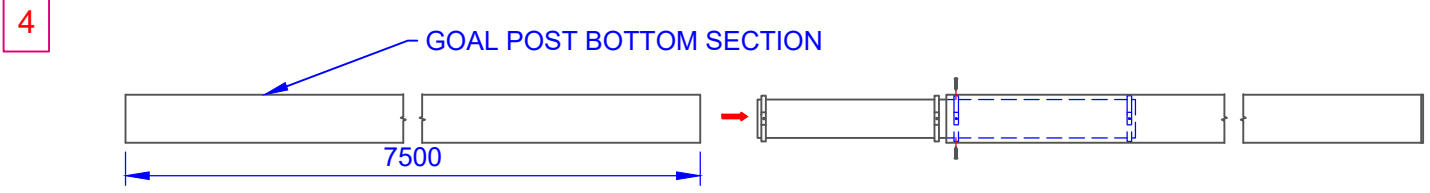
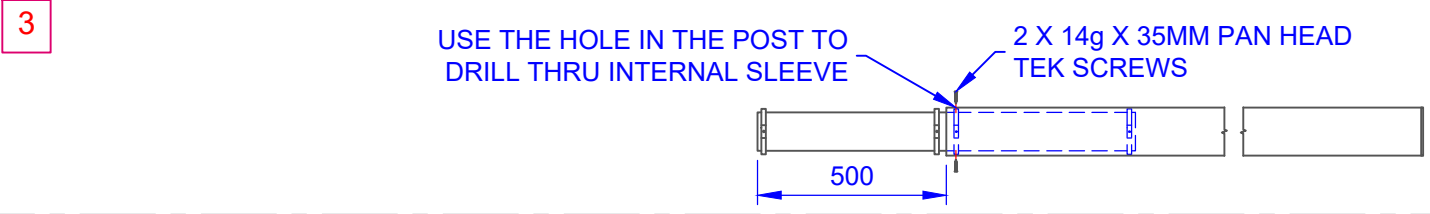
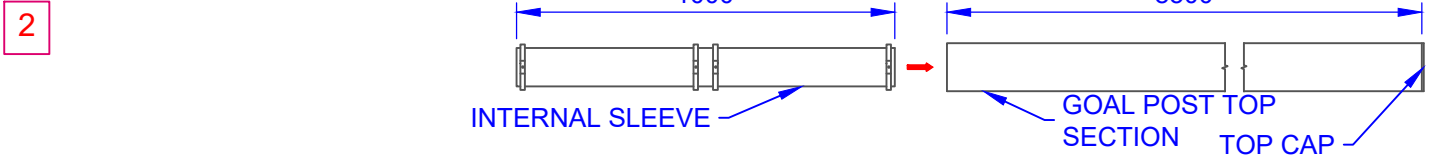
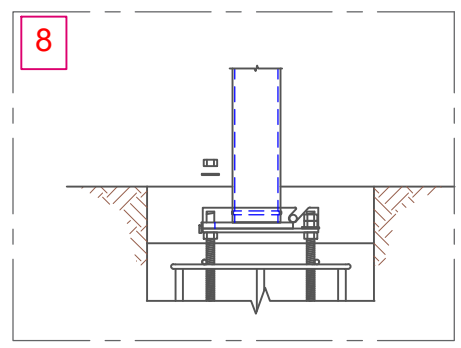
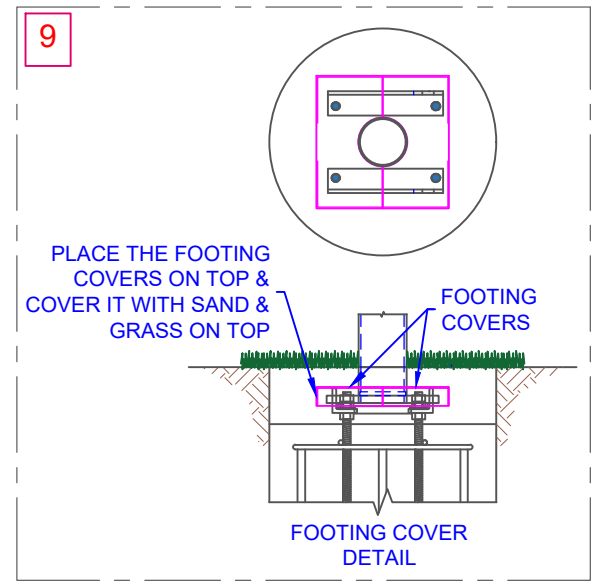

FOOTING INSTALLATION INSTRUCTIONS:

- STEP 1:** IDENTIFY THE COMPONENTS SUPPLIED USING THE PACKING LIST. CONTACT US AS SOON AS POSSIBLE IF ANY PARTS ARE MISSING.
- STEP 2:** SLIDE THE INTERNAL SLEEVE 500MM INSIDE THE TOP SECTION.
- STEP 3:** THEN, USING THE HOLES IN THE TOP SECTION DRILL 3 X HOLES INTO 5MM Ø HOLES INTO THE INTERNAL SLEEVE AND SCREW 2 X 14g X 35MM PAN HEAD TEK SCREWS.
- STEP 4:** THEN JOIN THE BOTTOM SECTION TO THE INTERNAL SLEEVE AND REPEAT STEP 3.
- STEP 5:** SLIDE IN THE POST SPIGOT INTO THE GOAL POST BOTTOM SECTION AND REPEAT STEP 3. REPEAT STEP 2 - 3 FOR BEHIND/POINT POST ASSEMBLY
- STEP 6:** THEN POSITION THE PIN AT THE SPIGOT INTO THE HINGE BRACKET.
- STEP 7:** USING A LIFTING AID RAISE THE POST UP. YOU CAN USE CROSS BAR ATTACHED ACROSS A TRACTOR REAR TO RAISE OR LOWER THE POSTS.
- STEP 8:** THEN FIX THE ASSEMBLY USING M20 NUT AND WASHER. THEY SHOULD BE PROPERLY TIGHTENED.
- STEP 9:** INSTALL FOOTING COVERS OVER THE BASE



TITLE: AR150 AFL GOAL POSTS ASSEMBLY DETAILS 2 OF 3	
DRAWING NUMBER: AR150	ISSUED ON: 19/08/2024
	
<small>Oz Ring Pty Ltd Trading as: Play Hard Sports Equipment ABN 79 066 094 559 24 Em Harley Drive Burleigh Heads Qld 4220 Phone: (07) 5593 4494 Fax: (07) 5593 4338 Website: www.playhardsports.com.au Email: email@playhardsports.com.au</small>	